

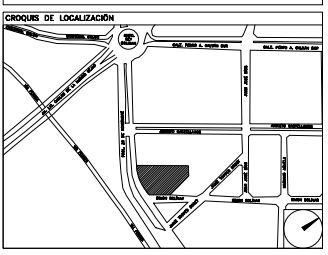

**CENTRO DE SERVICIO INFONAVIT
CESI / DELEGACIÓN / COLIMA**
**PROLONGACIÓN 20 DE NOVIEMBRE S/N ESQ. CON SIMÓN BOLIVAR
MZN 78 LT 15, COL. SAN PABLO, COLIMA, COLIMA**

PROYECTO EJECUTIVO

PLANOS:
HERRERÍAS



NÚMERO DEL PLANO: _____ NORTE: 

UBICACIÓN DEL ARCHIVO: _____



USO ESPECÍFICO DEL PREDIO: _____
 TIPO DE TRÁMITE: _____

DATOS DEL PROPIETARIO		DATOS GENERALES																																																	
NOMBRE: _____ No.: _____ CALLE: _____ COLONIA: _____ DELEGACIÓN: _____ TELÉFONO: _____ FIRMA: _____		<table border="1"> <tr> <th colspan="2">DATOS DEL PREDIO</th> <th colspan="2">USO</th> </tr> <tr> <td>CLAVE CATASTRAL:</td> <td></td> <td>HABITACIONAL</td> <td><input type="checkbox"/></td> </tr> <tr> <td>ÁREA:</td> <td>M2</td> <td>UNIFAMILIAR</td> <td><input type="checkbox"/></td> </tr> <tr> <td>LOTJE:</td> <td></td> <td>PLURIFAMILIAR (CONDOMINIO)</td> <td><input type="checkbox"/></td> </tr> <tr> <td>MEDIDA DEL FRENTE:</td> <td>FONDO: m</td> <td>COMERCIAL</td> <td><input type="checkbox"/></td> </tr> <tr> <td>DIRECCIÓN:</td> <td>No OFICIAL:</td> <td>SERVICIOS</td> <td><input type="checkbox"/></td> </tr> <tr> <td>CALLE:</td> <td></td> <td>INDUSTRIAL</td> <td><input type="checkbox"/></td> </tr> <tr> <td>ENTRE LA CALLE Y LA CALLE:</td> <td></td> <td></td> <td></td> </tr> <tr> <td>COLONIA:</td> <td></td> <td></td> <td></td> </tr> <tr> <td>DELEGACIÓN:</td> <td></td> <td></td> <td></td> </tr> <tr> <td>DICTAMEN DE USO DE SUELO</td> <td></td> <td></td> <td></td> </tr> <tr> <td>No. DE FOLIO:</td> <td>FECHA:</td> <td></td> <td></td> </tr> </table>		DATOS DEL PREDIO		USO		CLAVE CATASTRAL:		HABITACIONAL	<input type="checkbox"/>	ÁREA:	M2	UNIFAMILIAR	<input type="checkbox"/>	LOTJE:		PLURIFAMILIAR (CONDOMINIO)	<input type="checkbox"/>	MEDIDA DEL FRENTE:	FONDO: m	COMERCIAL	<input type="checkbox"/>	DIRECCIÓN:	No OFICIAL:	SERVICIOS	<input type="checkbox"/>	CALLE:		INDUSTRIAL	<input type="checkbox"/>	ENTRE LA CALLE Y LA CALLE:				COLONIA:				DELEGACIÓN:				DICTAMEN DE USO DE SUELO				No. DE FOLIO:	FECHA:		
DATOS DEL PREDIO		USO																																																	
CLAVE CATASTRAL:		HABITACIONAL	<input type="checkbox"/>																																																
ÁREA:	M2	UNIFAMILIAR	<input type="checkbox"/>																																																
LOTJE:		PLURIFAMILIAR (CONDOMINIO)	<input type="checkbox"/>																																																
MEDIDA DEL FRENTE:	FONDO: m	COMERCIAL	<input type="checkbox"/>																																																
DIRECCIÓN:	No OFICIAL:	SERVICIOS	<input type="checkbox"/>																																																
CALLE:		INDUSTRIAL	<input type="checkbox"/>																																																
ENTRE LA CALLE Y LA CALLE:																																																			
COLONIA:																																																			
DELEGACIÓN:																																																			
DICTAMEN DE USO DE SUELO																																																			
No. DE FOLIO:	FECHA:																																																		
DATOS DEL D.R.O NOMBRE: _____ CÉDULA PROFESIONAL: _____ DIRECCIÓN: _____ DELEGACIÓN: _____ TELÉFONO: _____ FIRMA: _____		NORMATIVIDAD <table border="1"> <thead> <tr> <th>CONCEPTO</th> <th>NORMA</th> <th>PROYECTO</th> <th>DEF.</th> </tr> </thead> <tbody> <tr> <td>ALTURA MÁXIMA PERMITIDA</td> <td></td> <td></td> <td></td> </tr> <tr> <td>COEFICIENTE DE OCUPACIÓN DEL SUELO</td> <td></td> <td></td> <td></td> </tr> <tr> <td>COEFICIENTE DE UTILIZACIÓN DEL SUELO</td> <td></td> <td></td> <td></td> </tr> <tr> <td>COEFICIENTE DE ABSORCIÓN DEL SUELO</td> <td></td> <td></td> <td></td> </tr> <tr> <td>PORCENTAJE DEL ÁREA LIBRE</td> <td></td> <td></td> <td></td> </tr> <tr> <td>RESTRICCIÓN AL FRENTE</td> <td></td> <td></td> <td></td> </tr> <tr> <td>CAJONES DE ESTACIONAMIENTO</td> <td></td> <td></td> <td></td> </tr> <tr> <td>RESTRICCIÓNES DEL USO DE SUELO</td> <td></td> <td></td> <td></td> </tr> </tbody> </table>		CONCEPTO	NORMA	PROYECTO	DEF.	ALTURA MÁXIMA PERMITIDA				COEFICIENTE DE OCUPACIÓN DEL SUELO				COEFICIENTE DE UTILIZACIÓN DEL SUELO				COEFICIENTE DE ABSORCIÓN DEL SUELO				PORCENTAJE DEL ÁREA LIBRE				RESTRICCIÓN AL FRENTE				CAJONES DE ESTACIONAMIENTO				RESTRICCIÓNES DEL USO DE SUELO															
CONCEPTO	NORMA	PROYECTO	DEF.																																																
ALTURA MÁXIMA PERMITIDA																																																			
COEFICIENTE DE OCUPACIÓN DEL SUELO																																																			
COEFICIENTE DE UTILIZACIÓN DEL SUELO																																																			
COEFICIENTE DE ABSORCIÓN DEL SUELO																																																			
PORCENTAJE DEL ÁREA LIBRE																																																			
RESTRICCIÓN AL FRENTE																																																			
CAJONES DE ESTACIONAMIENTO																																																			
RESTRICCIÓNES DEL USO DE SUELO																																																			
CORRESPBLE. INGENIERIAS NOMBRE: _____ CÉDULA PROFESIONAL: _____ DIRECCIÓN: _____ DELEGACIÓN: _____ TELÉFONO: _____ FIRMA: _____		FIRMA: _____																																																	

**RIVERO BORRELL - GUTIERREZ
ARQUITECTOS**

SELLO

ESCALA: 1 : 50

COTAS: METROS

CLAVE: HE-04

Este plano sustituye a los anteriores
 REVISIÓN - 00 / 27 abril 2018

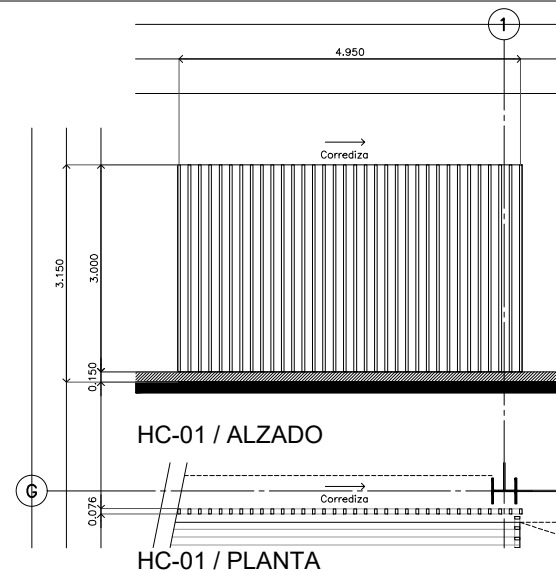

HC-01 / ALZADO

HC-01 / PLANTA

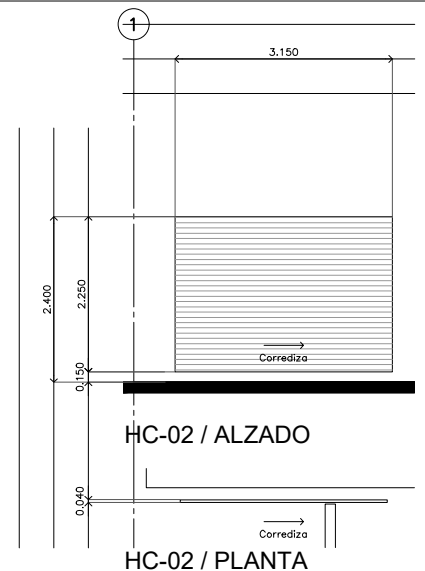

HC-02 / ALZADO

HC-02 / PLANTA

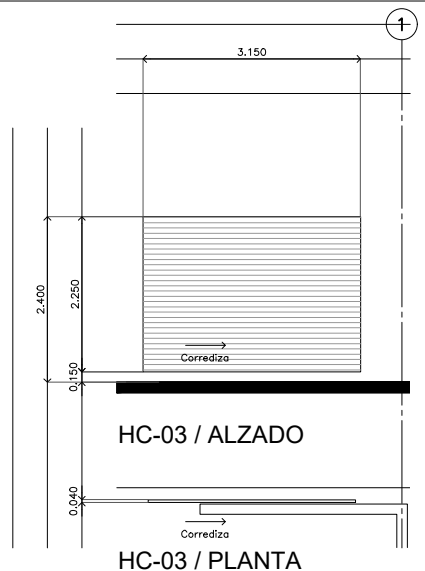

HC-03 / ALZADO

HC-03 / PLANTA

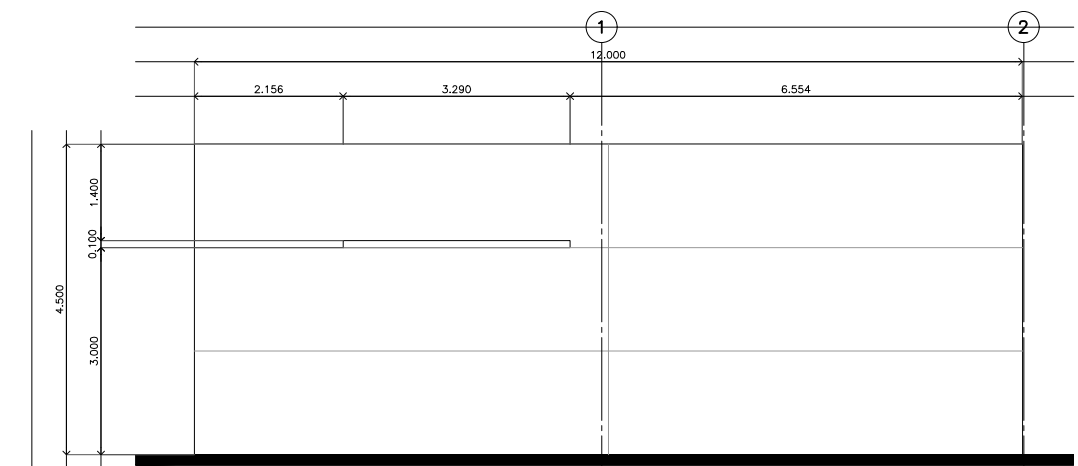

HF-01 / ALZADO

HF-01 / PLANTA

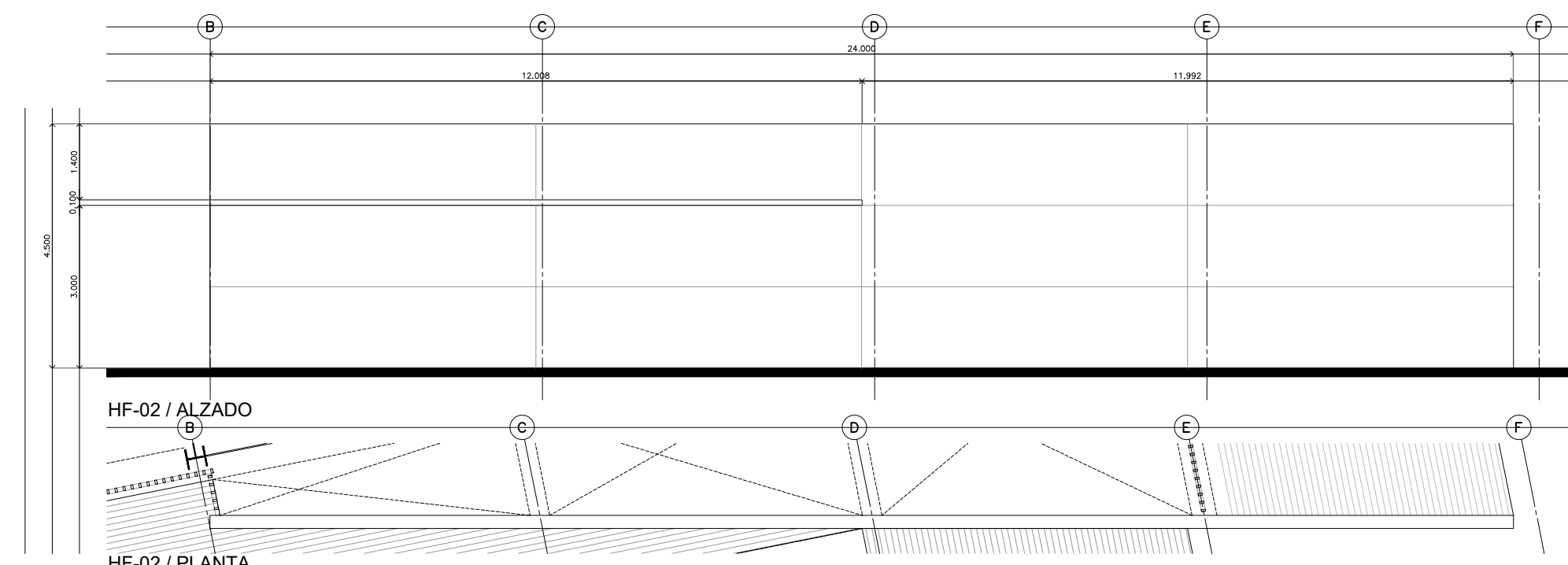

HF-02 / ALZADO

HF-02 / PLANTA