

CENTRO DE SERVICIO INFONAVIT / DEL SALTILLO
CALLE JOSÉ MARÍA LA FRAGUA ESQ. CON CALLE VERACRUZ COL. GUANAJUATO ORIENTE, SALTILLO, COAHUILA

<p align="center">PROYECTO EJECUTIVO</p> <p align="center">DETALLES</p>	
<p align="center">CRONOGRAMA DE LOCALIZACIÓN</p>	
<p>NÚMERO DEL PLANO:</p>	<p>NORTE:</p>
<p>UBICACIÓN DEL ARCHIVO:</p>	
<p>INFONAVIT</p>	

USO ESPECIFICO DEL PREDIO:
TIPO DE TRAMITE:

<p>DATOS DEL PROPIETARIO</p> <p>NOMBRE: _____ No. _____</p> <p>CALLE: _____</p> <p>COLOMIA: _____</p> <p>DELEGACION: _____</p> <p>TELEFONO: _____</p> <p>FIRMA: _____</p>		<p>DATOS GENERALES</p> <table border="1"> <tr> <th colspan="2">DATOS DEL PREDIO</th> <th>USO</th> </tr> <tr> <td>CLAVE CATASTRAL:</td> <td>AREA:</td> <td>HABITACIONAL <input type="checkbox"/></td> </tr> <tr> <td>LOTE:</td> <td>M2:</td> <td>UNIFAMILIAR <input type="checkbox"/></td> </tr> <tr> <td>MEDIDA DEL FRENTE:</td> <td>FONDO:</td> <td>PLURIFAMILIAR (CONDOMINIO) <input type="checkbox"/></td> </tr> <tr> <td>DIRECCION:</td> <td>m:</td> <td>COMERCIAL <input type="checkbox"/></td> </tr> <tr> <td>CALLE:</td> <td>No OFICIAL:</td> <td>SERVICIOS <input type="checkbox"/></td> </tr> <tr> <td>ENTRE LA CALLE Y LA CALLE:</td> <td></td> <td>INDUSTRIAL <input type="checkbox"/></td> </tr> <tr> <td>COLONIA:</td> <td></td> <td></td> </tr> <tr> <td>DICTAMEN DE USO DE SUELO</td> <td></td> <td></td> </tr> <tr> <td>FECHA:</td> <td></td> <td></td> </tr> </table>		DATOS DEL PREDIO		USO	CLAVE CATASTRAL:	AREA:	HABITACIONAL <input type="checkbox"/>	LOTE:	M2:	UNIFAMILIAR <input type="checkbox"/>	MEDIDA DEL FRENTE:	FONDO:	PLURIFAMILIAR (CONDOMINIO) <input type="checkbox"/>	DIRECCION:	m:	COMERCIAL <input type="checkbox"/>	CALLE:	No OFICIAL:	SERVICIOS <input type="checkbox"/>	ENTRE LA CALLE Y LA CALLE:		INDUSTRIAL <input type="checkbox"/>	COLONIA:			DICTAMEN DE USO DE SUELO			FECHA:								
DATOS DEL PREDIO		USO																																					
CLAVE CATASTRAL:	AREA:	HABITACIONAL <input type="checkbox"/>																																					
LOTE:	M2:	UNIFAMILIAR <input type="checkbox"/>																																					
MEDIDA DEL FRENTE:	FONDO:	PLURIFAMILIAR (CONDOMINIO) <input type="checkbox"/>																																					
DIRECCION:	m:	COMERCIAL <input type="checkbox"/>																																					
CALLE:	No OFICIAL:	SERVICIOS <input type="checkbox"/>																																					
ENTRE LA CALLE Y LA CALLE:		INDUSTRIAL <input type="checkbox"/>																																					
COLONIA:																																							
DICTAMEN DE USO DE SUELO																																							
FECHA:																																							
<p>DATOS DEL D.R.O</p> <p>NOMBRE: _____</p> <p>CEDULA PROFESIONAL: _____</p> <p>DIRECCION: _____</p> <p>DELEGACION: _____</p> <p>TELEFONO: _____</p> <p>FIRMA: _____</p>		<p>CORRESPBLE. INGENIERIAS</p> <p>NOMBRE: _____</p> <p>CEDULA PROFESIONAL: _____</p> <p>DIRECCION: _____</p> <p>DELEGACION: _____</p> <p>TELEFONO: _____</p> <p>FIRMA: _____</p>																																					
<p>NORMATIVIDAD</p> <table border="1"> <tr> <th>CONCEPTO</th> <th>NORMA</th> <th>PROYECTO</th> <th>DEF.</th> </tr> <tr> <td>ALTURA MAXIMA PERMITIDA</td> <td></td> <td></td> <td></td> </tr> <tr> <td>COEFICIENTE DE OCUPACION DEL SUELO</td> <td></td> <td></td> <td></td> </tr> <tr> <td>COEFICIENTE DE UTILIZACION DEL SUELO</td> <td></td> <td></td> <td></td> </tr> <tr> <td>COEFICIENTE DE ABSORCION DEL SUELO</td> <td></td> <td></td> <td></td> </tr> <tr> <td>PORCENTAJE DEL AREA LIBRE</td> <td></td> <td></td> <td></td> </tr> <tr> <td>RESTRICCION AL FRENTE</td> <td></td> <td></td> <td></td> </tr> <tr> <td>CAJONES DE ESTACIONAMIENTO</td> <td></td> <td></td> <td></td> </tr> <tr> <td>RESTRICCIONES DIC. USO DE SUELO</td> <td></td> <td></td> <td></td> </tr> </table>		CONCEPTO	NORMA	PROYECTO	DEF.	ALTURA MAXIMA PERMITIDA				COEFICIENTE DE OCUPACION DEL SUELO				COEFICIENTE DE UTILIZACION DEL SUELO				COEFICIENTE DE ABSORCION DEL SUELO				PORCENTAJE DEL AREA LIBRE				RESTRICCION AL FRENTE				CAJONES DE ESTACIONAMIENTO				RESTRICCIONES DIC. USO DE SUELO				<p>FIRMA: _____</p>	
CONCEPTO	NORMA	PROYECTO	DEF.																																				
ALTURA MAXIMA PERMITIDA																																							
COEFICIENTE DE OCUPACION DEL SUELO																																							
COEFICIENTE DE UTILIZACION DEL SUELO																																							
COEFICIENTE DE ABSORCION DEL SUELO																																							
PORCENTAJE DEL AREA LIBRE																																							
RESTRICCION AL FRENTE																																							
CAJONES DE ESTACIONAMIENTO																																							
RESTRICCIONES DIC. USO DE SUELO																																							

RIVERO BORRELL - GUTIERREZ
ARQUITECTOS

SELLO

<p>ESCALA:</p> <p align="center">1 : 50</p>	<p>COTAS:</p> <p align="center">METROS</p>	<p>CLAVE:</p> <p align="center">DE-20</p>
<p align="center">Este plano sustituye a los anteriores</p> <p align="center">REVISIÓN - 00 / 07 marzo 2018</p>		

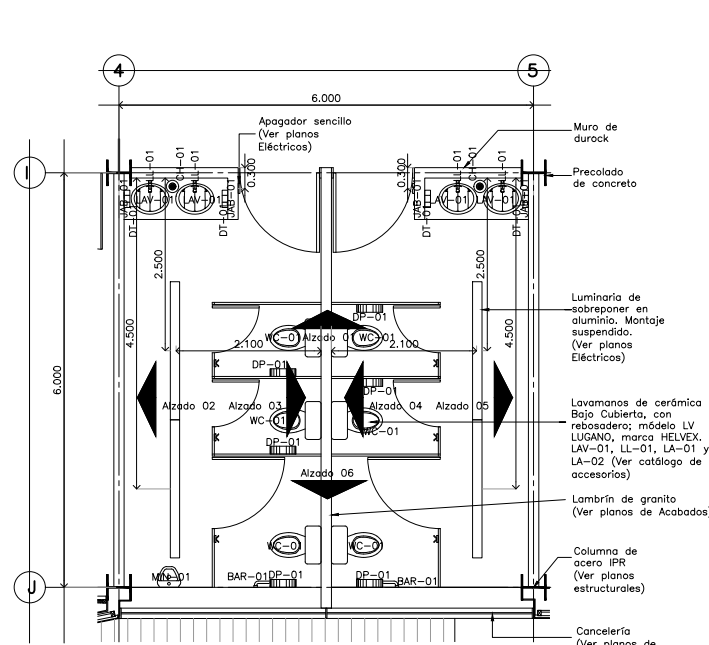

Detalle 33
Planta Sanitarios / Delegación
 Escala: 1:50

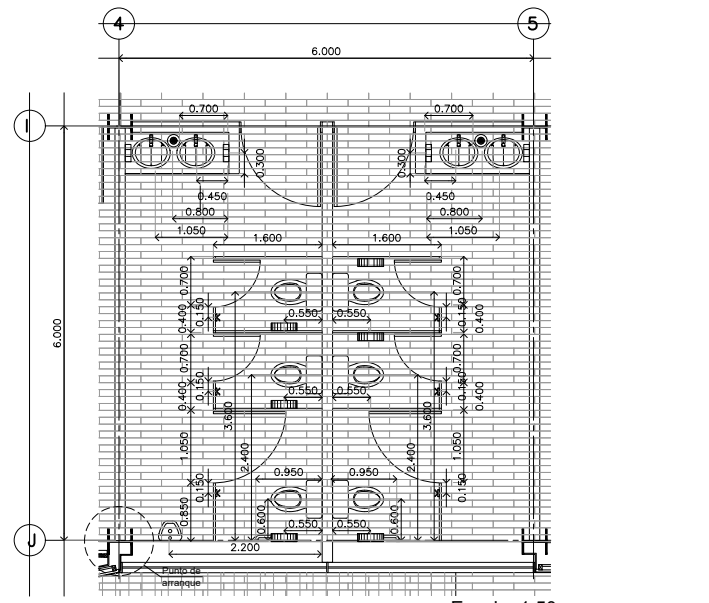

Detalle 33
Despiece de pisos
Planta Sanitarios / Delegación
 Escala: 1:50

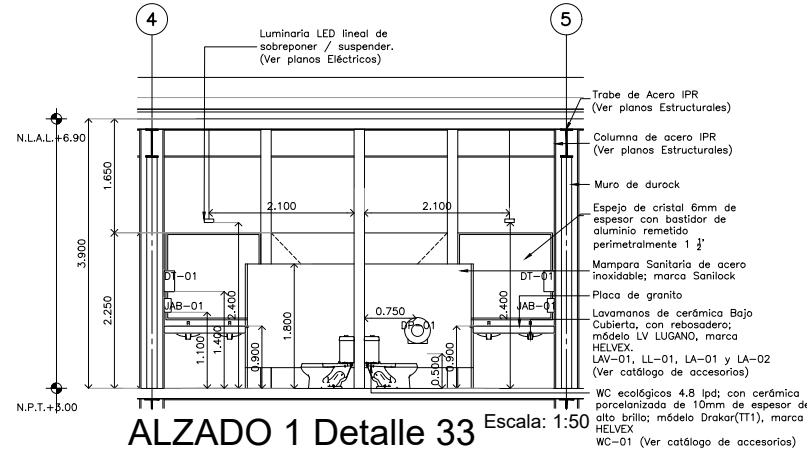

ALZADO 1 Detalle 33
 Escala: 1:50

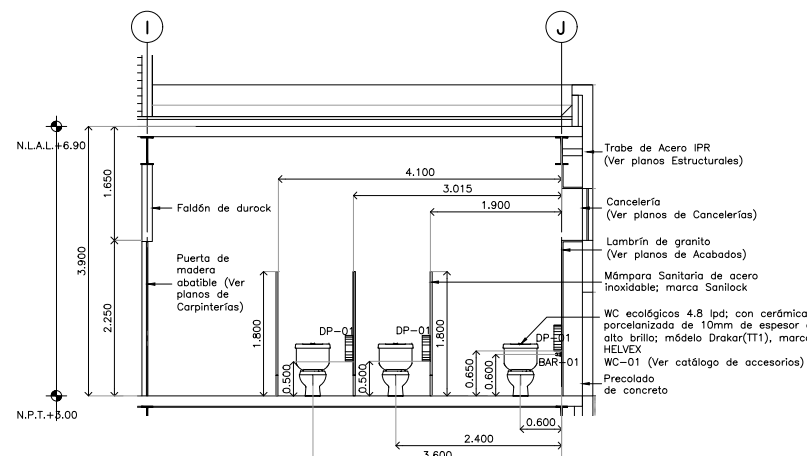

ALZADO 3 Detalle 33
 Escala: 1:50

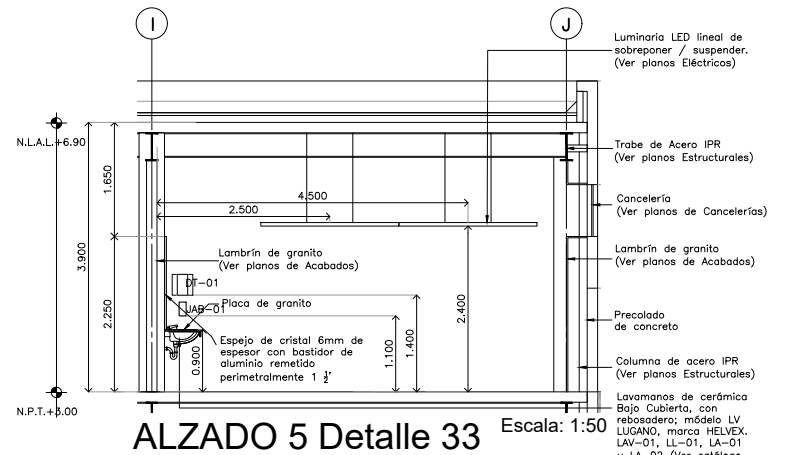

ALZADO 5 Detalle 33
 Escala: 1:50

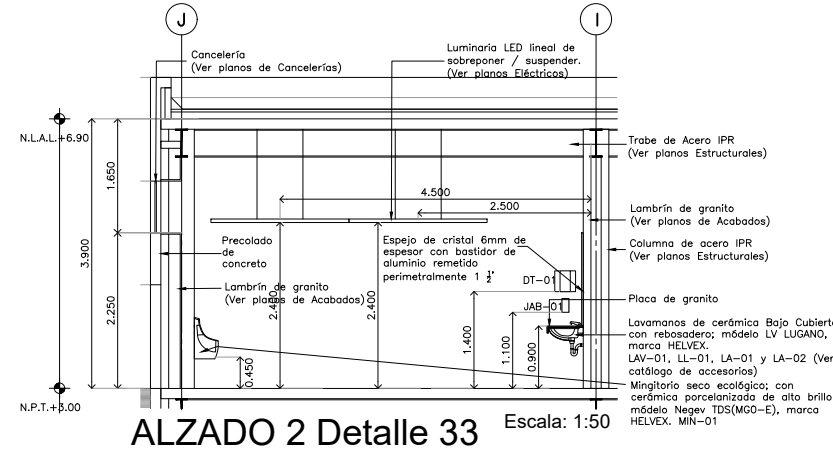

ALZADO 2 Detalle 33
 Escala: 1:50

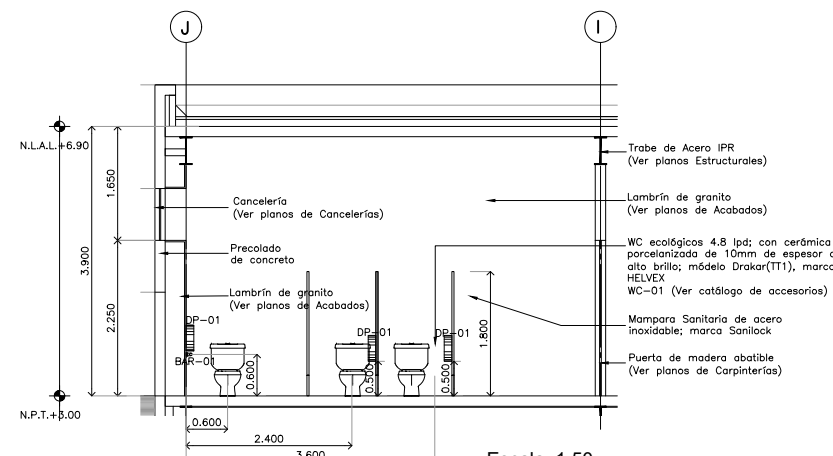

ALZADO 4 Detalle 33
 Escala: 1:50

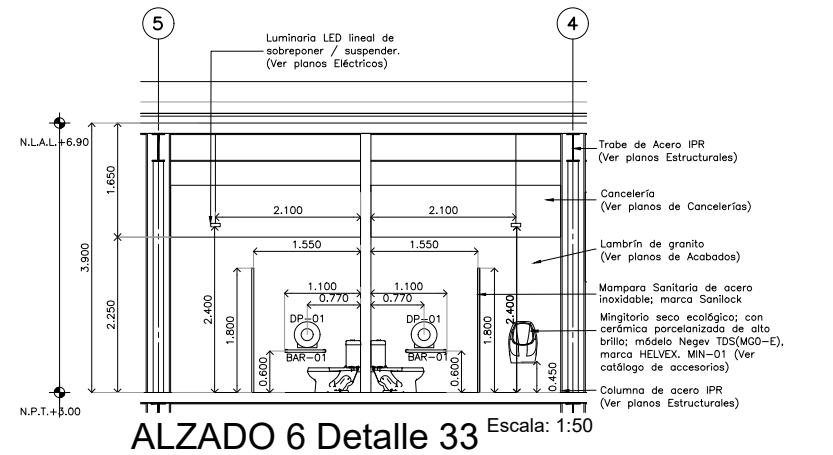

ALZADO 6 Detalle 33
 Escala: 1:50